

Flat Pattern view
SCALE: 1:5

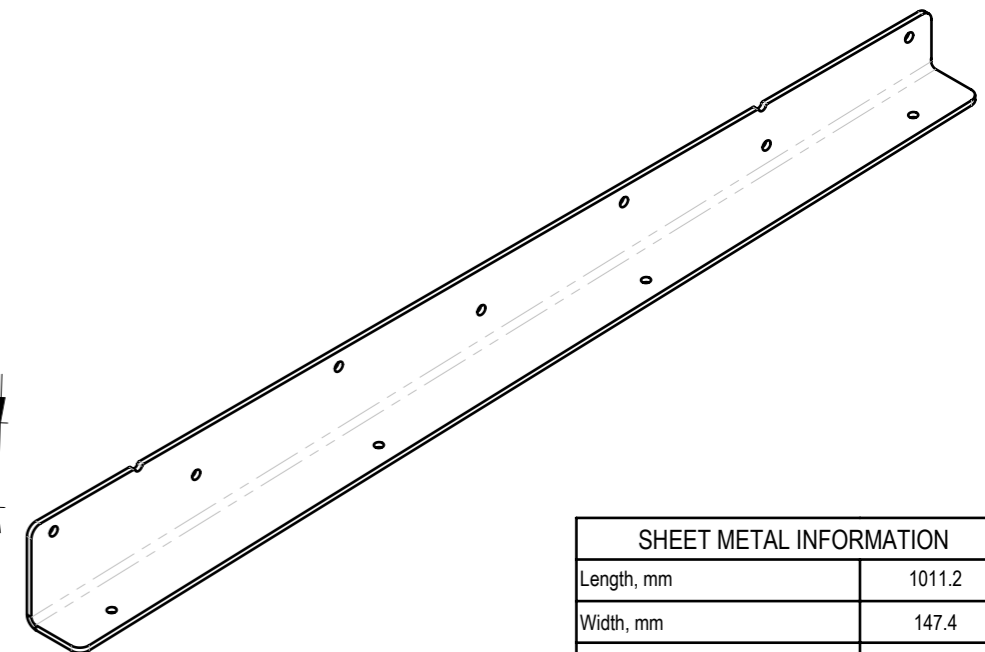
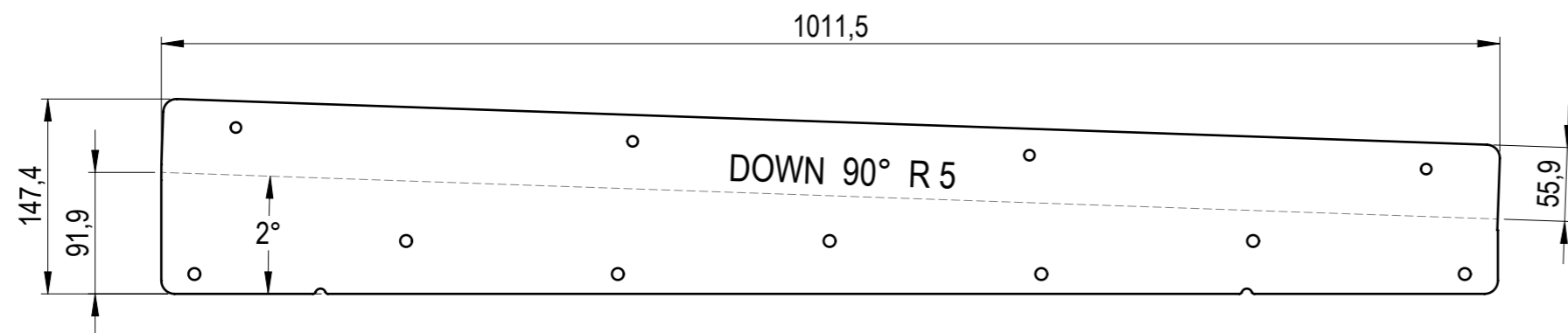

SHEET METAL INFORMATION	
Length, mm	1011.2
Width, mm	147.4
Thickness, mm	5
Inside Bend Radius, mm	5
K-Factor	0.5
No. of Bends	1

Other dimensions from .DXF file.

	MATERIAL	WEIGHT	DEBURR AND BREAK SHARP EDGES		REVISION	DATE
	S355J2	5.097 Kg	DO NOT SCALE DRAWING			14.04.2025
	SURFACE PROTECTION	MACHINING	THERMAL CUTTING	WELDING	SCALE	FORMAT
	HDG EN ISO 1461	ISO 2768 mK	ISO 9013 221	ISO 13920 BF	1:5	A3
	NAME	SIGNATURE	PART NO.			
Designed by	E. Kamols		105-06000-05			
Drawn by	E. Kriviss		DESCRIPTION			
Technical ref.			Top plywood support plate R			SHEET 1/1